



OWNER'S MANUAL

STK Series Gen 2 Electric Chain Hoist



Table of Contents

1.0 Important Safety Information	4
1.1 Safety Precautions	4
1.2 Warnings	4
2.0 Product Specifications.....	5
3.0 Service Life	6
3.1 Determining the FEM Hoist Duty Service Classification	6
3.2 Load Spectrum	7
3.2.1 Light Use.....	7
3.2.2 Medium Use.....	7
3.2.3 Heavy Use	7
4.0 Lifting Motor Usage Data.....	9
5.0 Safety Features.....	9
6.0 Pendant Options	10
7.0 Electrical and Chain Information.....	11
8.0 Mechanical Drawings & Data	12
8.1 ½ Ton Model	12
8.2 1 Ton Model	13
8.3 2 Ton Model	14
8.4 3 Ton Model	15
8.5 5 Ton Model	16
9.0 Safety Tips for Overhead Crane Operation	17
10.0 Installation.....	18
10.1 Unpacking	18
10.2 Power Requirements	18
10.3 Upper hook assembly	18
10.4 Chain Bag	18
10.5 Electrical Connection	19
10.6 Operational Testing.....	19
11.0 Operation	20
12.0 Maintenance	21
12.1 General Maintenance	21
12.2 Daily Pre-Use Inspection (No Load).....	21
12.3 Monthly Inspection.....	22
12.2.3 Annual Overhaul	23

13.0 Electrical Information.....	24
13.1 Starke Single Speed Hoist Motor Horsepower & Amp Information.....	25
14.0 Parts Orders.....	25
15.0 Part Lists and Exploded Drawings.....	26
15.1 Motor and Body Assembly Diagram.....	26
15.2 Motor and Body Assembly Part List.....	27
15.2 Motor and Body Assembly Part List (Continued).....	28
15.3 Hook Assembly 2A Assembly Diagram (1/2, 1, 2, 3 Ton).....	30
15.4 Hook Assembly 2A Part List (1/2, 1, 2, 3 Ton).....	31
15.5 Hook Assembly 2B Diagram Assembly (5 Ton).....	32
15.6 Hook Assembly 2B Part List (5 Ton).....	33
15.7 Gear Box Assembly Diagram.....	34
15.8 Gear Box Part List.....	35
15.9 Chain Assembly Diagram.....	36
15.10 Chain Assembly Part List.....	37
15.11 Electrical Box.....	38
16.0 Troubleshooting Guide.....	39
17.0 Derated Hoist Information.....	41
Starke Products Warranty.....	42

1.0 Important Safety Information

Please read, understand, and follow all aspects of this manual before the assembly and installation of this hoist system. Please observe and follow all safety and warning information during the operation of this system. Failure to do so may result in serious property damage, personal injury and/or loss of life.

1.1 Safety Precautions

Because of the heavy loads being transported by this system, the operator and those around the serviceable area must be attentive to and aware of all potential risks involved with the operation of this system. The operator must pay careful attention to and abide by the safety rules and warnings listed below and found throughout this manual. All Safety Rules and Warnings must be followed.

1.2 Warnings

- Before operation, the operator must have a clear and unobstructed view of the entire service area of this system.
- For your safety do not attach the electrical supply wires to this unit before the completion of installation!
- Before operation, inspect the hoist system to be sure it is in proper working condition. Check for any possible obstacles and/or personnel in the service area of the hoist system.
- While operating the hoist system, the operator must take caution to prevent a situation where the changing of direction of travel and the resulting abrupt force may cause the load to swing. This may cause an overload of the trolley and/or hoist and loss of the load.
- Do not modify this unit in any way or operate the unit in an overloaded or damaged condition. Any attempt to do so will put you, others, and property at serious risk.
- Repairs to this unit must be performed by a qualified repair facility. Contact Starke America to locate the nearest repair facility. See warranty information at the end of this manual.

2.0 Product Specifications

Design relative humidity %: $\leq 85\%$ RH

Design Temperature Rating: 60F to 104F (Normal Operating Range)

Protection Class:

- Hoist: IP54
- Pendant: IP54

Hoist Noise: 81 (dB)

If the working environmental conditions are outside of the recommended values in the table, please consult your dealer for further guidance.

The standard noise measurement is read at 1 meter from the hoist under normal operation.

3.0 Service Life

The service life expectancy and safe operation of the electric chain hoist can be realized only if it is operated in accordance to the following. The European Materials Handling Federation, known as 'FEM' are a standard body for the material handling industry and are publishers of the FEM Hoist Duty Classifications.

The design of this hoist conforms to the rating 1Am of FEM (Table 2.21)

3.1 Determining the FEM Hoist Duty Service Classification

When the load spectrum and the average daily operating time of the hoist are identified, the duty service classification of the hoist is obtained from this table.

The average operation hours per day and total operation hours are calculated based on load distribution.

$$t = \frac{2 * H * N * T}{V * 60}$$

- H = average hoisting height in meters
- N = the number of work cycles per hour
- T = the daily working time in hours
- V = the hoist speed (meters per minute)

Load Spectrum	Average Daily Operating Time ISO/FEM (hours per day)					
	≤0.5	≤1	≤2	≤4	≤8	≤16
Light			M3 1Bm	M4 1Am	M5 2m	M6 3m
Medium		M3 1Bm	M4 1Am	M5 2m	M6 3m	M7 4m
Heavy	M3 1Bm	M4 1Am	M5 2m	M6 3m	M7 4m	
Very Heavy	M4 1Am	M5 2m	M6 3m	M7 4m		

3.2 Load Spectrum

The load spectrum is the magnitude of the load over the duration of the hoist's operation and the calculated daily operating time. The basis for calculations is in accordance with FEM standards that a hoist has a 10-year serviceable lifetime.

3.2.1 Light Use

Light use would be defined as occasional full loads, usually light loads and small fixed loads (typically a light duty workshop crane with single shift operation).

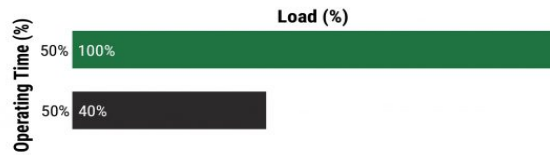

3.2.2 Medium Use

Medium use would be defined as occasional full loads, usually light loads and average fixed loads (usually a medium duty workshop crane with single shift operation).

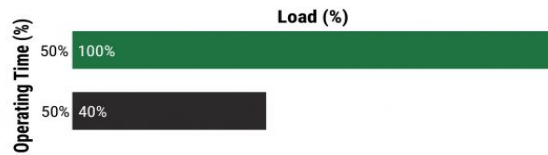

3.2.3 Heavy Use

Heavy use would be defined as repetitive full loads, usually average loads, and heavy fixed loads (expected to be a heavy-duty crane with one or to shift options).

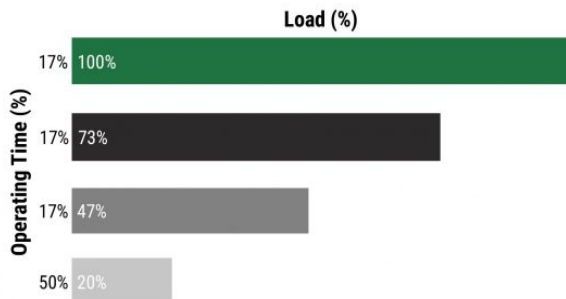

3.2.4 Very Heavy Use

Very Heavy use would be defined as usually almost full loads and very heavy fixed loads (this would be two to three shift operations with magnets below the hooks).

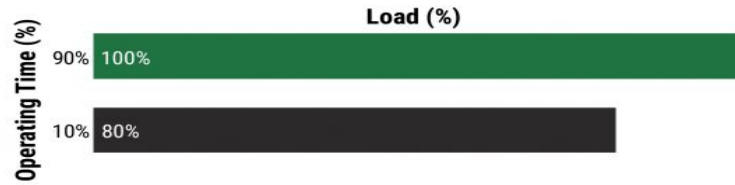

4.0 Lifting Motor Usage Data

Group		Intermitted operation			Continuous Operation
F.E.M	ISO	Cycles/h	Starts/h	ED(%)	Operation cycle/min
1 DM	M1	15	90	15	7.5
1 CM	M2	20	120	20	7.5
1 BM	M3	25	250	25	15
1 AM	M4	30	180	30	15
2M	MS	40	240	40	30
3M	M6	50	300	50	30
4M	M7	60	360	60	60
SM	MS	60	360	60	>60

5.0 Safety Features

5.1 Magnetic slide brake is a unique design by which it releases when the motor stator is energized, and the magnetic field pulls the brake hub from the friction cup. When power is removed it immediately engages and halts the motor's rotation.

5.2 The hook is forged of high tensile strength steel and heat treated to ensure maximum rigidity and hardness. It is equipped with a spring-loaded safety latch for securing lifting rigging devices in place. The lower hook assembly is supported within a ball bearing structure to allow easy rotation of the load.

5.3 The control system includes high quality electrical contactors and is protected with a standard phase monitoring system to ensure proper operation. This is to ensure that the motor is protected in the case of a power loss from incoming power supply and proper rotational direction of the lifting motor.

5.4 Upper and lower lifting limit switch is standard equipment on our Starke hoists to prevent damage to the chain and pulley system in the event of an operator error.

5.5 Control pendant options are all equipped with an emergency stop (Estop) button that is a manual reset type. This is to immediately stop all functions of the hoist system in the event of an emergency, it can also be used to secure the hoist system from unintentional activation.

6.0 Pendant Options

Pendant modes of motion are to be specified to dealer upon ordering hoist.

- a. In a fixed position installation of the hoist a 1-motion pendant would be required.
- b. If a hoist and motorized trolley is specified then a 2-motion pendant would be required.
- c. If a hoist, motorized trolley, and motorized bridge are specified then a 3-motion pendant is required.
- d. Another option is a wireless pendant control system that again can be customized to your application by your Starke America dealer.



1 Motion Pendant



2 Motion Pendant

7.0 Electrical and Chain Information

Capacity (Ton)	0.5	1	2	3	5
Chain Fall	1	1	1	1	2
Lifting Height Std.	20'				
Chain Dimension (mm)	6.3	7.1	10.0	11.2	11.2
Lifting Speed (FPM)	26	26	26	21	11
Supply Voltage	230/60/3 460/60/3				
E.D. Rating (%)	40	40	40	40	40
Control Voltage	24VAC	24VAC	24VAC	24VAC	24VAC

Load Chain

Grade 80 case hardened alloy steel chain endures harsh conditions including moisture, salt water, and some chemicals. Oil chain per recommendations in this manual.

8.0 Mechanical Drawings & Data

8.1 1/2 Ton Model

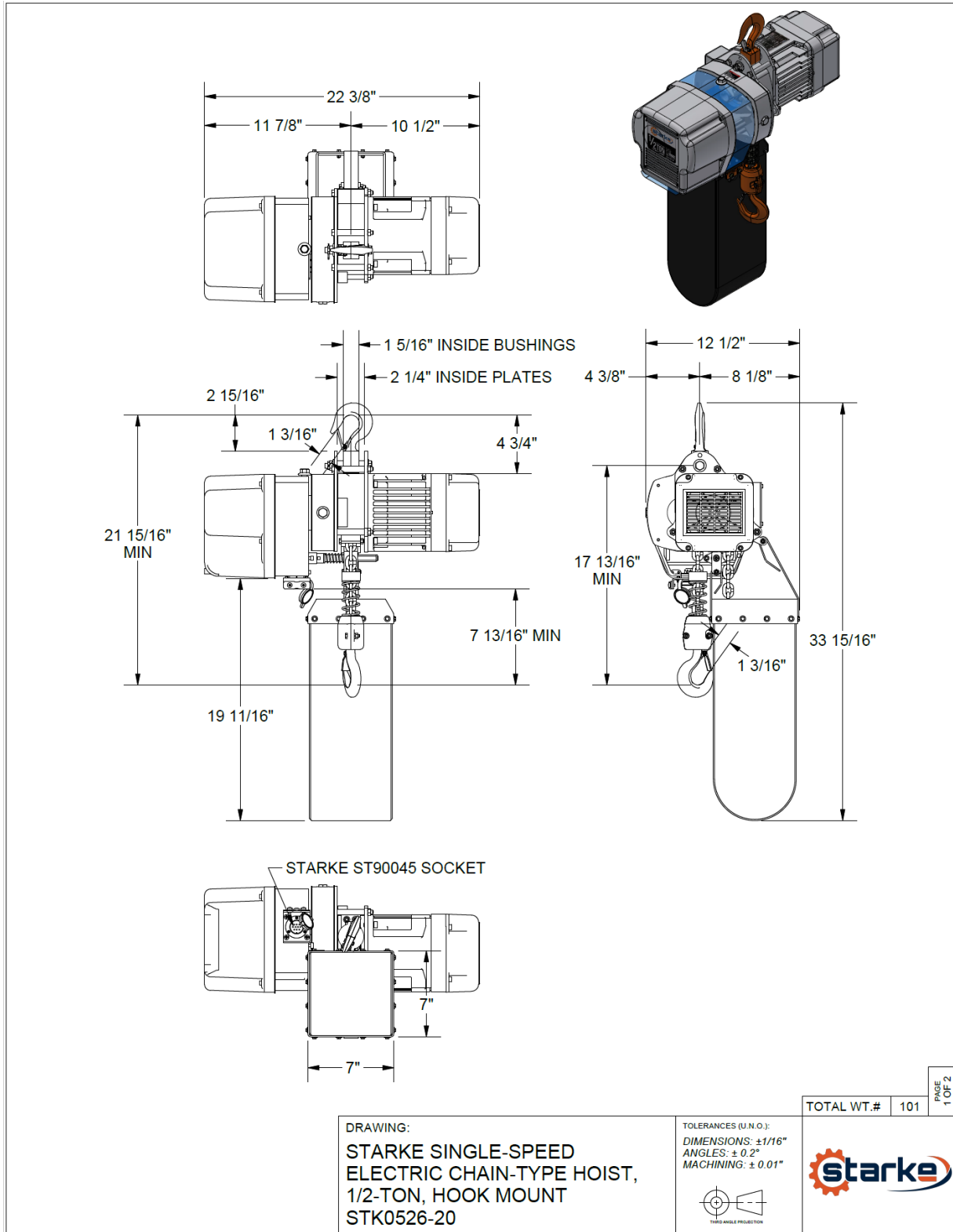

8.2 1 Ton Model

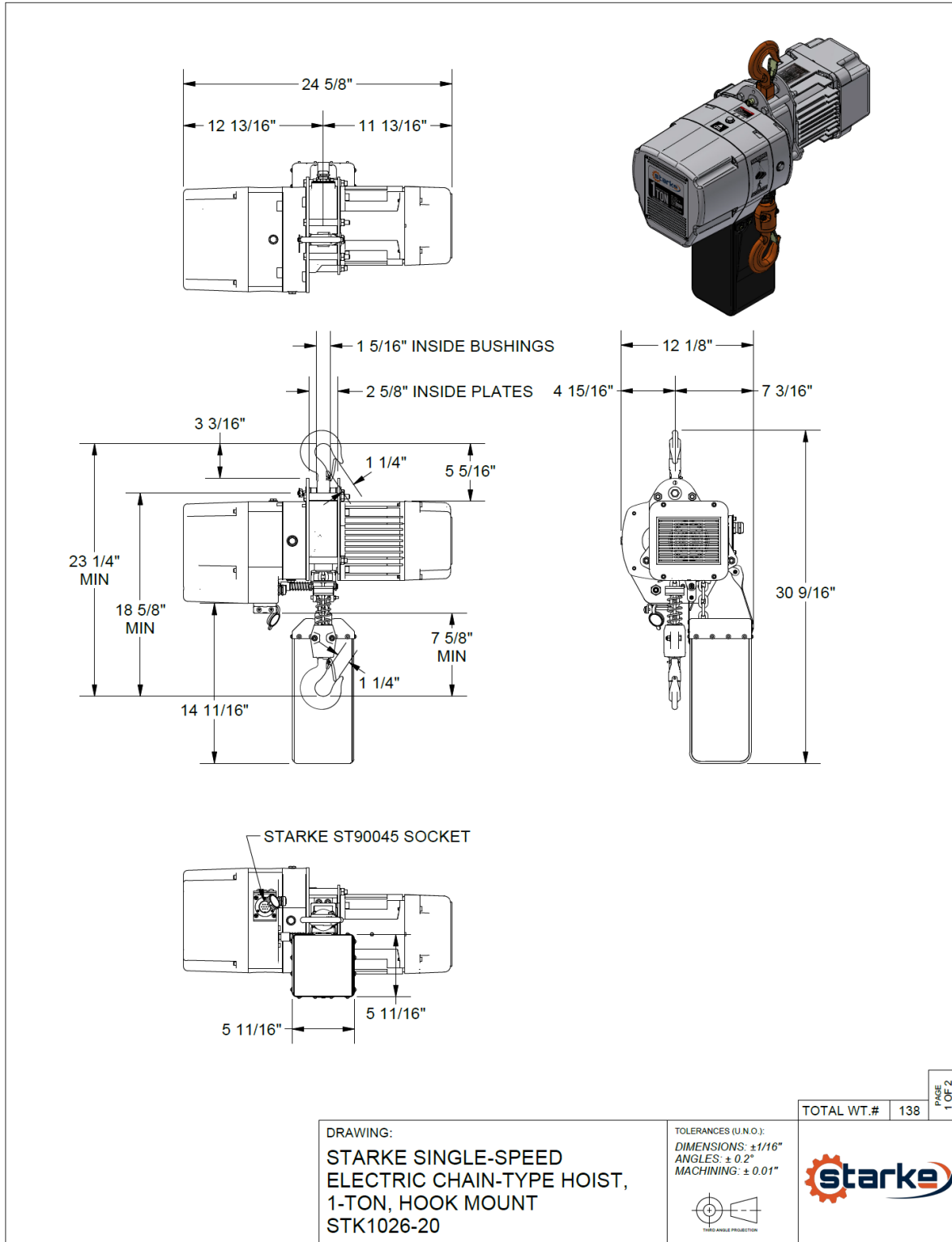

8.3 2 Ton Model

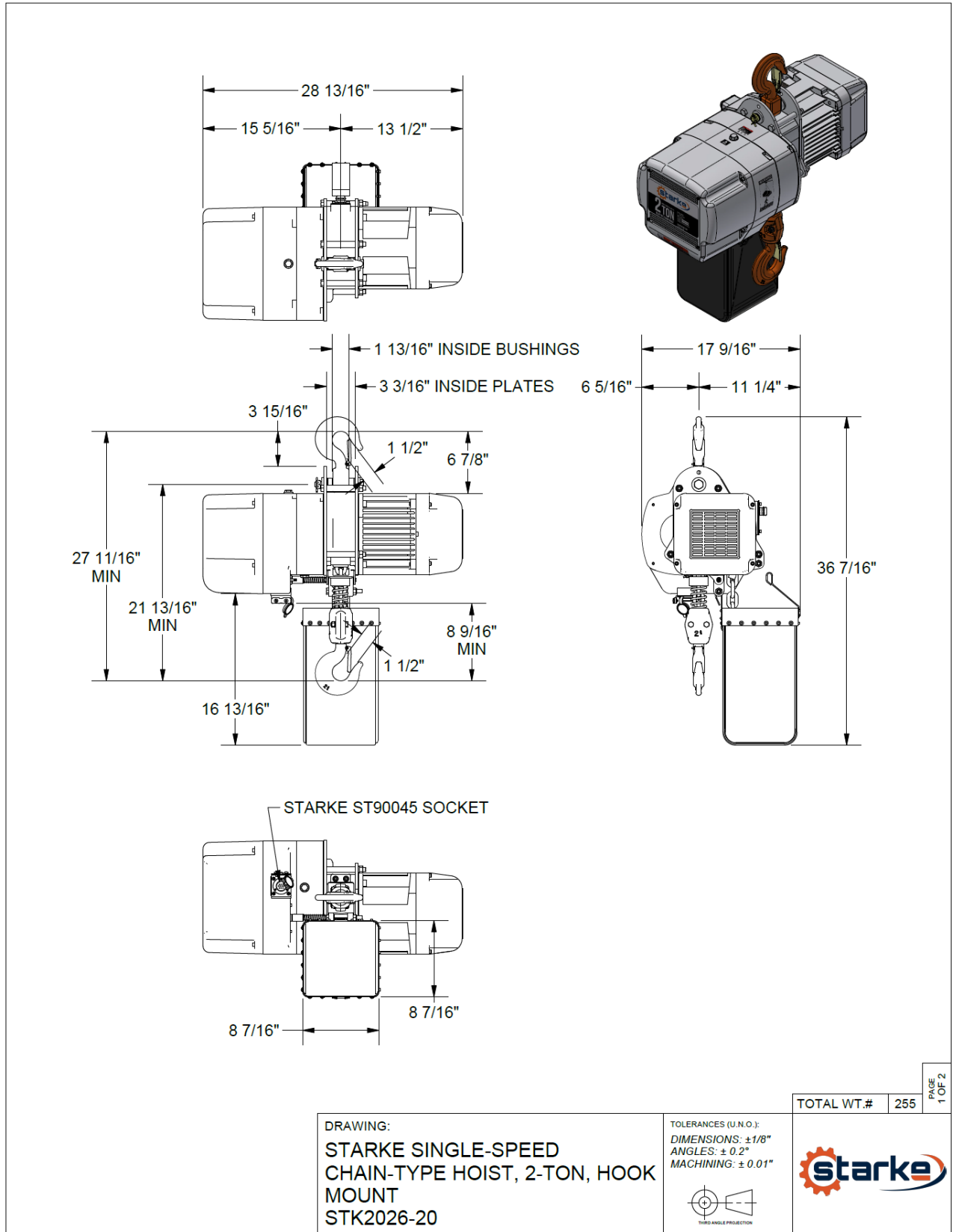

8.4 3 Ton Model

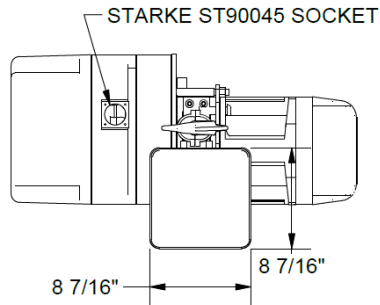
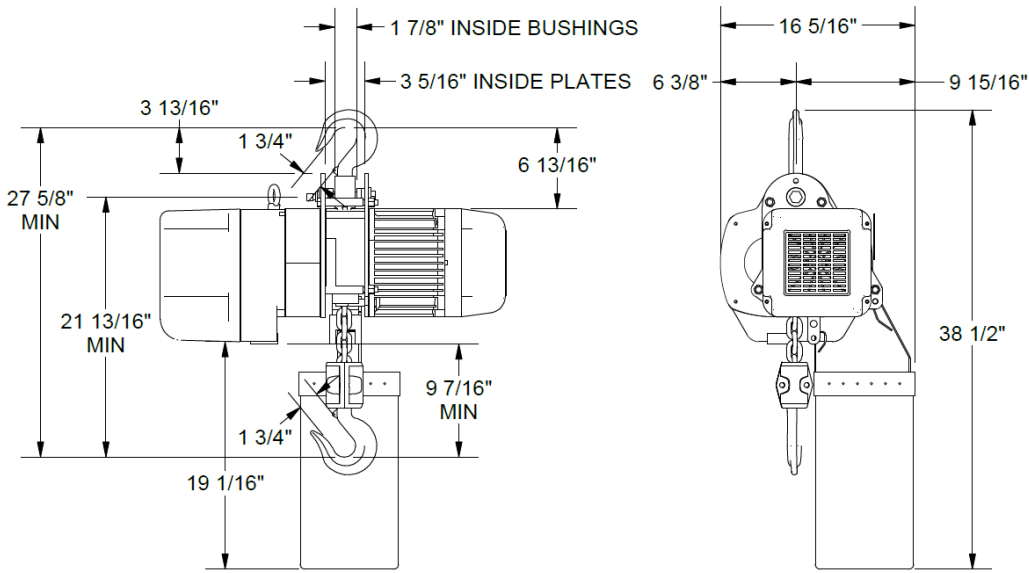
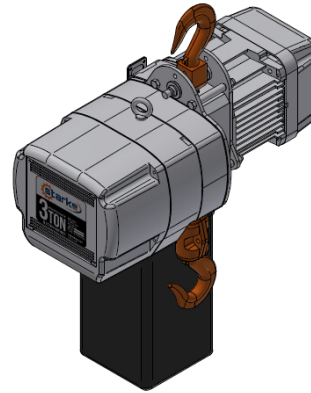
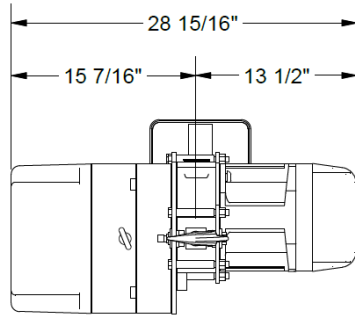

DRAWING:
**STARKE SINGLE-SPEED
 ELECTRIC CHAIN-TYPE HOIST,
 3-TON, HOOK MOUNT
 STK3021-20**

TOLERANCES (U.N.O.):
 DIMENSIONS: $\pm 1/8"$
 ANGLES: $\pm 0.2^\circ$
 MACHINING: $\pm 0.01"$



TOTAL WT.# 262

PAGE
1 OF 1



8.5 5 Ton Model

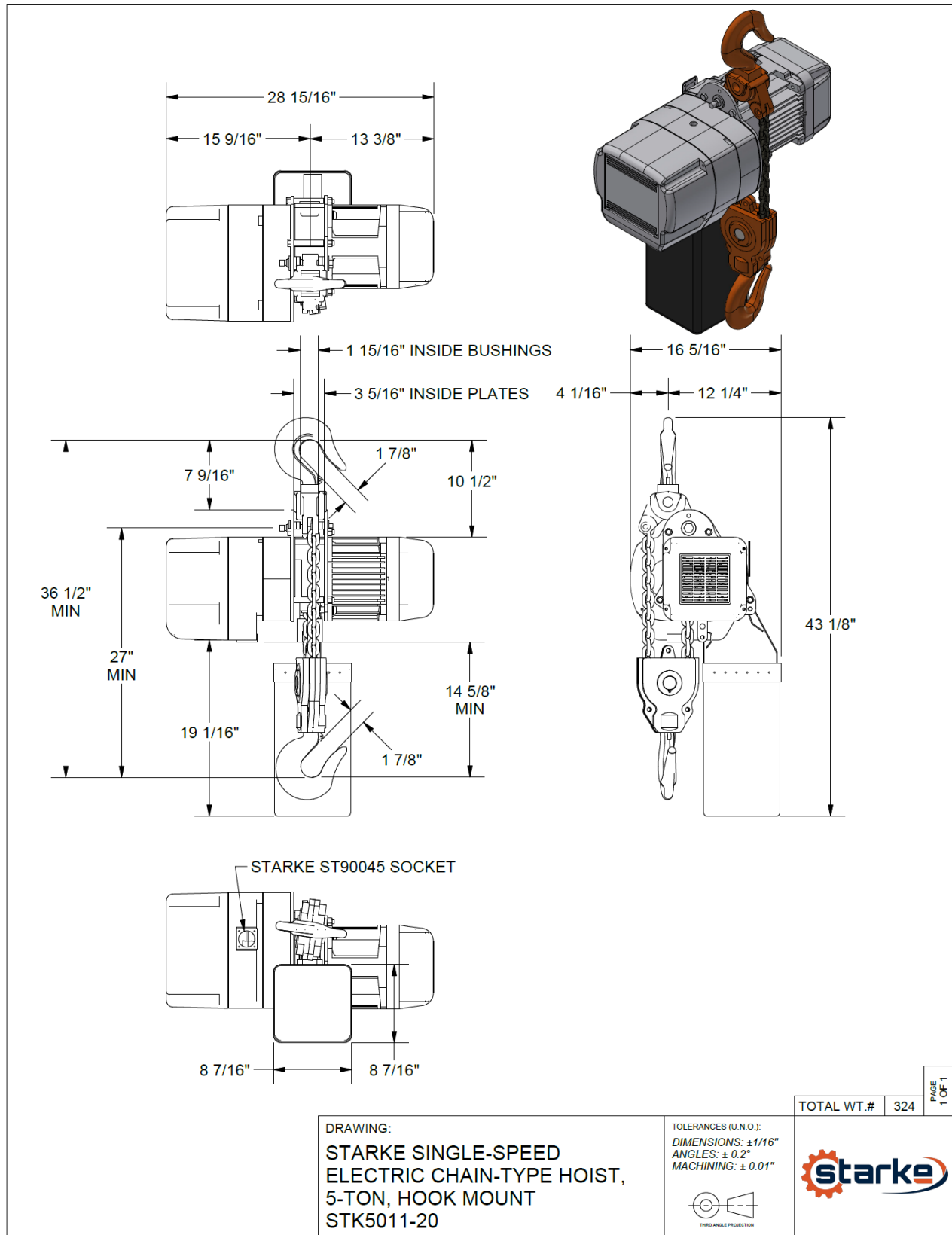

9.0 Safety Tips for Overhead Crane Operation

- Before use, ensure the crane is suitable for the planned hoisting task. Confirm it has appropriate travel, lift, and capacity.
- Visually and physically inspect the crane before use. Check for damage, wear, and proper operation of all functions.
- Confirm the load weight. Check the capacity of all equipment including the hardware, rope, and slings. Do not exceed these capacities.
- Select the right sling for each lift. Inspect slings and other rigging hardware before use for wear, stretch, or other damage. Do not use damaged or defective slings. Use softeners around sharp corners. Do not splice broken slings.
- When communicating with a crane operator, use clear agreed-upon signals. Except for the stop signal, the crane operator should follow instructions from only one person – a designated signaler. Where a wired or remote controller is used, the operator should become familiar with all of its functions before lifting the load.
- Warn all people in the load lift area before starting the lift. Ensure that the path of the load is clear of persons and obstructions. Do not lift loads over anyone. Center the crane hoist over the load before hoisting to prevent swinging of the load.
- Slide the sling fully onto the hoisting hook and ensure the safety latch is closed. Do not load the hook tip or hammer a sling into place.
- Secure unused sling legs. Do not drag slings or leave loose materials on a load being hoisted.
- Keep hands and fingers from being trapped when slack is taken out of a sling. Step away before the lift is started.
- Move the load and controls smoothly. Minimize load swing.
- Walk ahead of the load during travel and warn people to keep clear. Use a tagline to prevent rotation or other uncontrolled motion. Raise the load only as high as necessary to clear objects. Do not ride on the hook or load.
- Set loads down on blocking, never directly on a sling. Do not pull or push loads out from under the hoist.
- Do not leave the load (or the crane) unattended while the load is suspended.
- Where crane operation by other personnel must be restricted, employ lockout and tagging procedures.
- Store slings off the floor in a clean, dry location on hooks or racks. Do not leave slings, accessories, or blocking lying on the floor.

10.0 Installation

10.1 Unpacking

Upon opening the crate that the hoist is shipped in, please inspect the hoist for any signs of damage to the power cable, gearbox, and motor shell that may have occurred during shipping. You should find in the crate, the hoist, chain bag, control pendant, bottle of chain oil, and the owners documentation.

10.2 Power Requirements

Please verify the power supply voltage you intend to use matches the hoist, by default the hoist will be configured for 460Vac 3 phase power. The hoist can be ordered wired for 230Vac 3 phase operation or can be field modified prior to installation if required (see schematic for wiring chart).

The power supply voltage should be +/- 10% of the operating voltage the hoist is configured for. If the hoist is operated outside of this specification damage to the lifting motor is possible.

▲IMPORTANT NOTE: Do not connect the power supply prior to completing the physical installation of the hoist system. Potential damage and/or injury may occur.

10.3 Upper hook assembly

Before installing the hoist, please confirm the entire upper hook assembly has been completely assembled and mounted to the hoist body securely. (5 ton only) Check that the chain connecting pin for the lift chain is securely in place at the hoist body. (All models) Hang the hoist to the support structure carefully and check all fasteners are secured.

▲IMPORTANT NOTE: If the hoist system is equipped with a Starke motorized trolley the hook will be omitted and the suspension lug will be required to attach the hoist to the trolley.

10.4 Chain Bag

Install chain bag to the bottom of hoist body with the supplied hardware, note that the brackets on the chain bag are offset slightly to allow the bag to hang level.

10.5 Electrical Connection

As a precaution, please confirm the power supply matches the power requirements of the hoist system. Connect the power supply and verify proper phasing to the hoist system, this hoist has a phase monitoring system and may not allow hoist to operate properly if phasing is incorrect.

It is recommended that a qualified installer perform the set up and testing of this system.

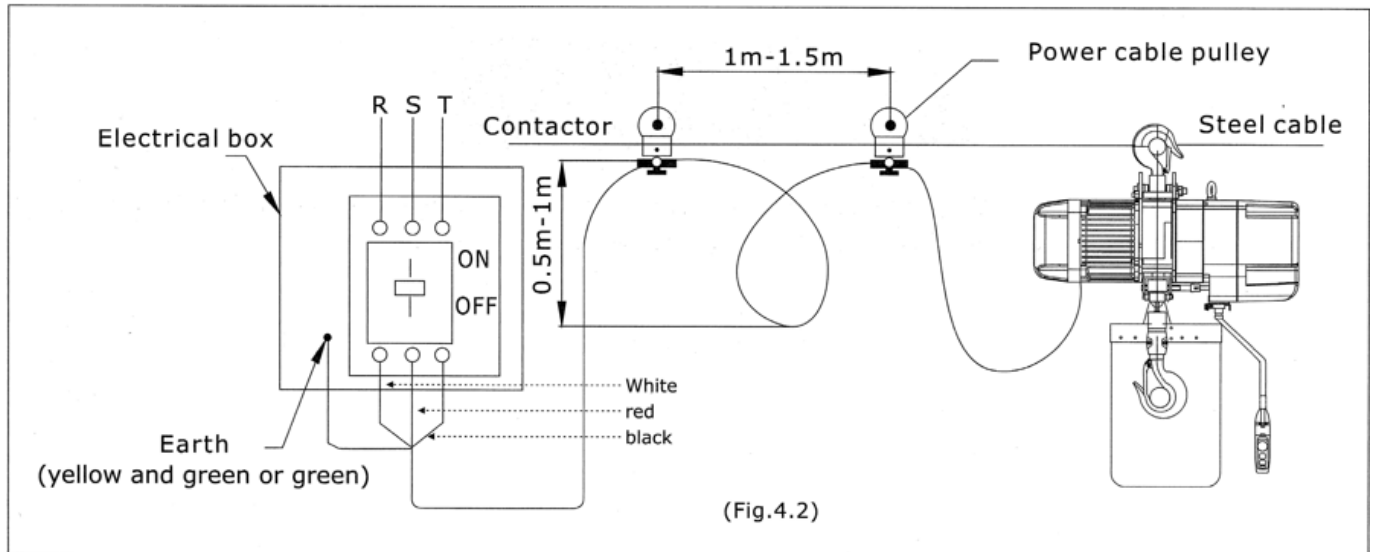

10.6 Operational Testing

- Test the emergency stop button on the control pendant. With the E-stop button depressed the hoist should not operate when any pendant button is activated. If any button activates hoist while E-stop is depressed, do not use the hoist and contact your dealer for further information. If all is well then grab the E-stop button and rotate clockwise, the button should pop up and make a slight clicking sound, at this time proceed to the next test.



- Verify chain is not twisted or askew by examining the individual chain link weld points. For proper operation the weld points must be in a parallel orientation as shown below (left). If the chain is reeved and twisted observe the illustration below (right) to remove twist in chain.
- Press the down button on the pendant and hold until the limit spring on the chain touches the limit switch plate, when the limit trips the hoist lifting motor should stop.
- Next press the up button on the pendant and hold until the chain is retracted fully upward, and the limit switch is tripped and lifting motor stops.

Lubrication of the chain will play an important part in the service lifetime of the hoist system. On initial installation apply the bottle of oil (included) to the chain and evenly disperse with cloth. The best method is to extend the chain to the lowest point then start applying lubricant at the base of the hoist and working your way down the chain to hook. After application run the chain fully up and fully down several times to insure even dispersion of oil on all moving parts.

11.0 Operation

After all the appropriate assembly and checkout has been completed it is now time to have the hoist system "Pre-Use inspected" by a qualified crane service provider and document any deficiencies that may be discovered and correct them. Once all commissioning and testing is complete the hoist system can be placed into service.

It is recommended to have an operator certification process that includes training by a qualified agency and following the safety tips in section 3 (Page 16) of this manual. Properly certified operators may help reduce potential risks in day-to-day use of the system and protect your employees from injury and property damage. Knowing proper operation of the hoist system will also maximize the service life of the system to your business and return on the investment you made in this Starke hoist.

12.0 Maintenance

12.1 General Maintenance

Your new Starke chain hoist requires very little maintenance, but there are some key items that should be done on a regular basis to prolong the longevity of the lifting device.

12.1.1 The most important and often overlooked item would be proper lubrication of the lift chain. Using the recommended oil **Lubriplate Rock Drill Oil 10R, #L0847-057** or equivalent.

- Wipe oil on with brush and coat all of the chain starting at the top with no load on the hook and the chain fully extended.
- Wipe excess oil off the chain with a rag, leaving a thin film of oil on the chain.
- Run chain up to upper limit to lubricate the internal moving parts

12.1.2 Check the chain guide for wear at the point where the chain enters the housing. Excessive wear from side pulling will require replacing the chain guide found on page 36, item 6, in the parts breakdown.

12.1.3 Check the gear oil level. Use the plug on the side of the hoist that is midway up on the side of the housing. Remove this plug and check if oil comes out. If no oil leaks out, remove the oil fill plug on the top of the hoist and add the recommended **ISO VG46 hydraulic oil** or equivalent until it starts to run out the side plug hole.

12.2 Daily Pre-Use Inspection (No Load)

- Verify power is available and test the operation of the Estop function.
- b. Test upper and lower limit switch functionality on hoist and any other motions the system is capable of.
- As the motor is operating listen for any unusual sounds such as grinding or excessive humming, hammering, stuttering. If so, place the hoist out of service until properly inspected by qualified personnel.
- Check chain condition and look for any signs of excessive wear or foreign debris and that adequate lubrication is present. Correct as necessary.
- Inspect hook assembly for signs of damage or wear and that hook safety latch is in good condition.

▲IMPORTANT NOTE: Keep a daily log or checklist of these results and run times of the system per day. Good record keeping will help when planning for routine maintenance of the system and maximizing service life.

12.3 Monthly Inspection

Included with the hoist is a chain test gauge that is attached to the pendant cable. This offers a convenient way to perform the following checks. See figures below for reference.

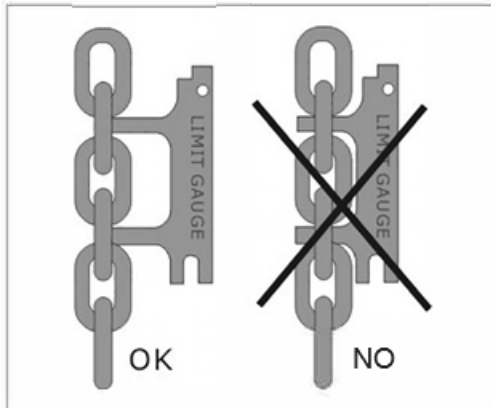

12.3.1 Intermodal Distance

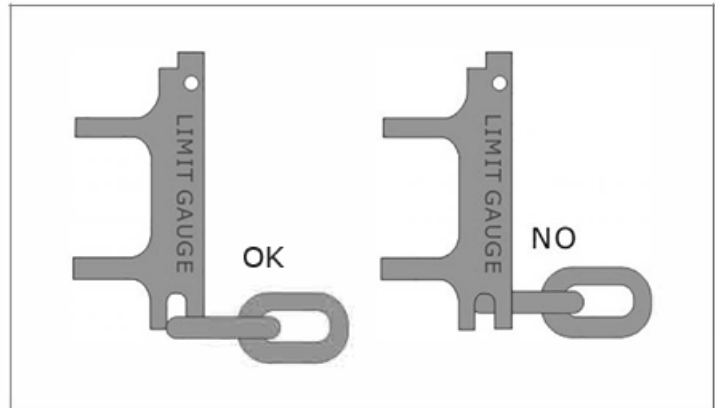

12.3.2 Diameter Gauge

- Perform a thorough inspection of the chain. Look for excessive wear on chain links as well as distortion or stretching of the links. Measure internal and external length dimensions of the links. See table 6.1 for nominal dimensions and if the measured values exceed 5% of specifications the chain must be replaced.
- Inspect the chain link diameter and if the measured value is 10% less than the specified diameter the chain must be replaced.

- Inspect hoist hook assembly checking for any cracks or distortion of the hook body and/or excessive wear. If the measured dimensions are 5% or more out of specification the hook assembly needs replaced. See figure 6.2 and table 6.2 for specifications.

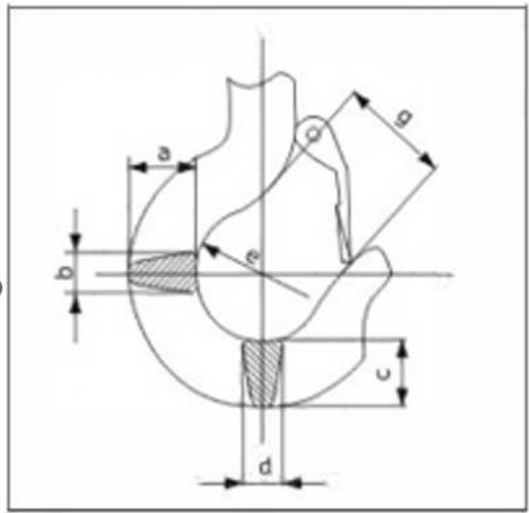

Figure 6.2

Capacity	A	B	C	D	E	G
½ Ton	27mm	18mm	25mm	17mm	35mm	28mm
1 Ton	34mm	24mm	30mm	24mm	42mm	32mm
2 Ton	46mm	29mm	39mm	30mm	49mm	40mm
3 Ton	56mm	35mm	49mm	34mm	59mm	48mm
5 Ton	67mm	43mm	57mm	44mm	60mm	48mm

- Test the limit switch for proper operation and that it freely pivots and returns to its resting position. It is recommended to apply a thin layer of lubrication during this procedure. If the limit switch is not working correctly then it should be replaced by a qualified service facility.

12.2.3 Annual Overhaul

The overhaul of the hoist should be performed by a qualified service facility. For assistance in obtaining repair of the hoist please contact your dealer or Starke America.

- Inspect chain drive gear and guide roller casement for wear and replace if required.
- Change gear case lubricant and inspect old lubricant for signs of metallic debris that could indicate excessive component wear within the drive train.
- Upon completion of overhaul the hoist should be load tested and certified by a qualified service agency before being placed back into service.

13.0 Electrical Information

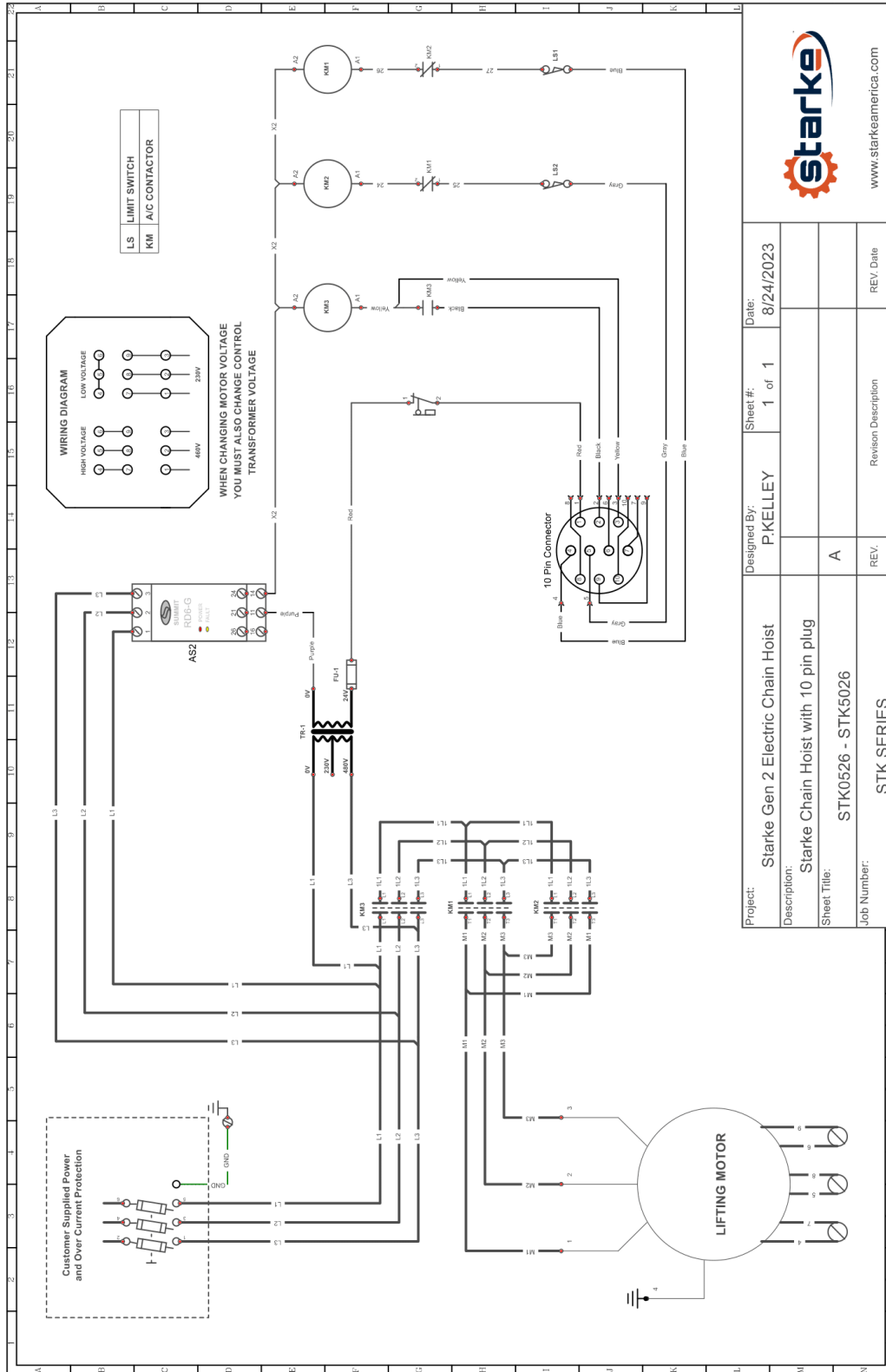

Project:	Starke Gen 2 Electric Chain Hoist	Designed By:	P.KELLEY	Sheet #:	1 of 1	Date:	8/24/2023
Description:	Starke Chain Hoist with 10 pin plug						
Sheet Title:	STK0526 - STK5026						
Job Number:	STK SERIES	REV.	Revision Description	REV.	REV.	REV.	REV. Date



13.1 Starke Single Speed Hoist Motor Horsepower & Amp Information

Capacity	Horsepower	Amps
½ Ton	1	2.1
1 Ton	2	3.4
2 Ton	4	6.3
3 Ton	4	6.3
5 Ton	4	6.3

14.0 Parts Orders

The following pages show parts breakdowns for each capacity hoist and the various parts and components for that particular capacity. When ordering parts for your Starke hoist please provide:

1. The version number of this manual
2. Page number of the part breakdown drawing
3. Item number from the part breakdown
4. Description of the part
5. Qty of each part you need

In the case there is no actual part number listed the above information will help us get you the correct part for your hoist.

Visit StarkeAmerica.com for parts availability & price requests via the “Contact Us” button.

15.0 Part Lists and Exploded Drawings

15.1 Motor and Body Assembly Diagram

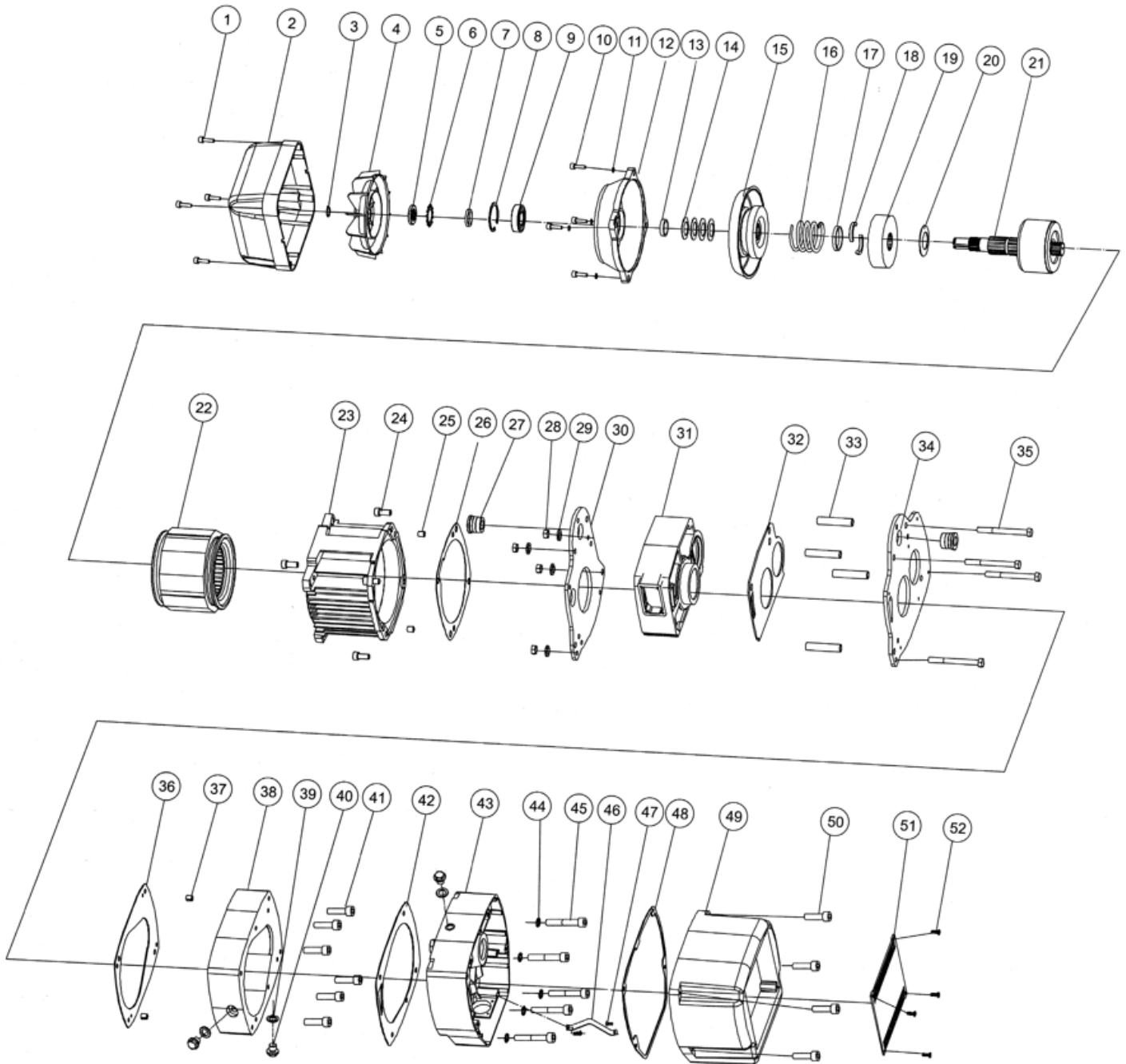

15.2 Motor and Body Assembly Part List

Drawing No.	Part Description	Qty
1	Cap Screw	4
2	Fan Cover	1
3	Washer	1
4	Fan Blade	1
5	Nut	1
6	Fan Lock Ring	1
7	Washer	1
8	Circlip	1
9	Rear Bearing	1
10	Cap Screw	4
11	Split Washer	4
12	Motor Rear Cover	1
13	Rotor Washer	1
14	Rear Brake Spring	4
15	Brake Pad Assembly	1
16	Brake Front Spring	1
17	Brake Drum Lock Spring	1
18	Brake Drum Lock Spring	1
19	Friction Block	1
20	Retaining Washer	1
21	Rotor Assembly	1
22	Stator Assembly	1
23	Motor Housing	1
24	Cap Screw	4
25	Boss Pin	2
26	Gasket A	1
27	Hoist Mount Pin Bushing (Motor Side)	2
28	Hex Nut	4
29	Split Washer	1
30	Motor Front Plate	1
31	Chain Drive Sprocket Case	1
32	Gasket B	1
33	Sleeve	4
34	Hoist Mount Pin Bushing (Gearbox Side)	1
35	Sleeve Through Bolt	4
36	Gasket C	4
37	Boss Pin	1
38	Gear Box Mid Section	3
39	Drain Plug Washer	3
40	Drain Plug Bolt	6

15.2 Motor and Body Assembly Part List (Continued)

Drawing No.	Part Description	Qty
41	Cap Screw	1
42	Gasket D	1
43	Gear Box Bearing Section	1
44	Lock Washer	4
45	Cap Screw	4
46	Cover Lanyard	2
47	Phillips Recess Head Screw	1
48	Gasket E	1
49	Electrical Box Cover	1
50	Cap Screw	4
51	Cover End Plate	1
52	Slotted Countersink Screw	4

(Intentionally Left Blank)

15.3 Hook Assembly 2A Assembly Diagram (1/2, 1, 2, 3 Ton)

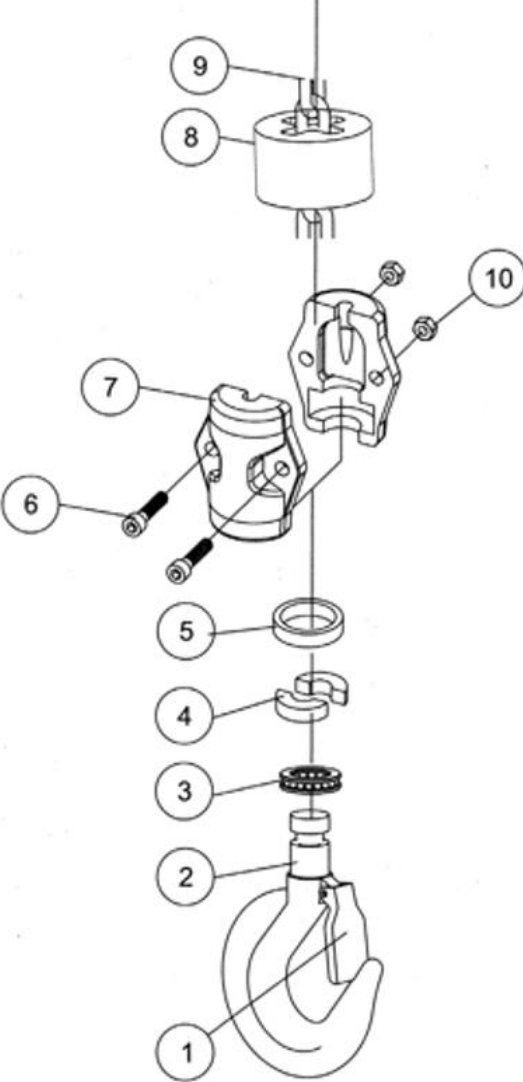

15.4 Hook Assembly 2A Part List (1/2, 1, 2, 3 Ton)

Drawing No.	Part Description	Part Number					Qty
		½ Ton	1 Ton	2 Ton	3 Ton	5 Ton	
1	Hook Safety Latch	600-50012	600-50013	600-50014	600-50015		1
2	Lower Hook Assy Includes: 1-7, 10	600-50023	600-50024	600-50025	600-50026	600-50027	1
3	Thrust Ball Bearing	NSS	NSS	NSS	NSS	NSS	1
4	Lower Hook Split Ring	NSS	NSS	NSS	NSS	NSS	2
5	Lower Hook Lock Sleeve	NSS	NSS	NSS	NSS	NSS	1
6	Cap Screw	NSS	NSS	NSS	NSS	NSS	2*
7	Lower Hook Swivel Casing	NSS	NSS	NSS	NSS	NSS	1
8	Rubber Stop	600-40036	600-40036	600-40037	600-40038	600-40038	1
9	Chain	See Chain Assy Drawing					1
10	Nyloc Nut	NSS	NSS	NSS	NSS	NSS	2
11	Pin	NSS	NSS	NSS	NSS	NSS	1*
12	Bolt	NSS	NSS	NSS	NSS	NSS	4*
13	Lower Load Block Case	NSS	NSS	NSS	NSS	NSS	1*
14	Needle Roller Bearing	NSS	NSS	NSS	NSS	NSS	2*
15	Lower Load Block Shift	NSS	NSS	NSS	NSS	NSS	1*
16	Lower Chain Sprocket	NSS	NSS	NSS	NSS	NSS	1*
17	Nut	NSS	NSS	NSS	NSS	NSS	4*
18	Split Washer	NSS	NSS	NSS	NSS	NSS	1*
19	Cotter Pin	NSS	NSS	NSS	NSS	NSS	1*
20	Keyed Hex Nut	NSS	NSS	NSS	NSS	NSS	1*
21	Chain Secure Bolt	NSS	NSS	NSS	NSS	NSS	1*
22	Chain Attachment Block	NSS	NSS	NSS	NSS	NSS	1*

15.6 Hook Assembly Part List (5 Ton)

Drawing No.	Part Description	Qty
1	Hook Safety Latch	1
2	Lower Hook	1
3	Hook Thrust Bearing	1
4	Split Keeper Ring	2
5	Bearing Thrust Plate	1
8	Rubber Stop	2
9	Chain 11.2 mm	1
11	Shaft Aligning Pin	1
12	Body Bolt	3
13	Block body	2
14	Bearing	2
15	Shaft	1
16	Pocket Wheel- Lower	1
17	Nut	3
18	Washer	1
19	Cotter Pin	1
20	Slotted Nut	1
21	Chain Connection Block Pin	1
22	Chain Connection Block	1

15.7 Gear Box Assembly Diagram

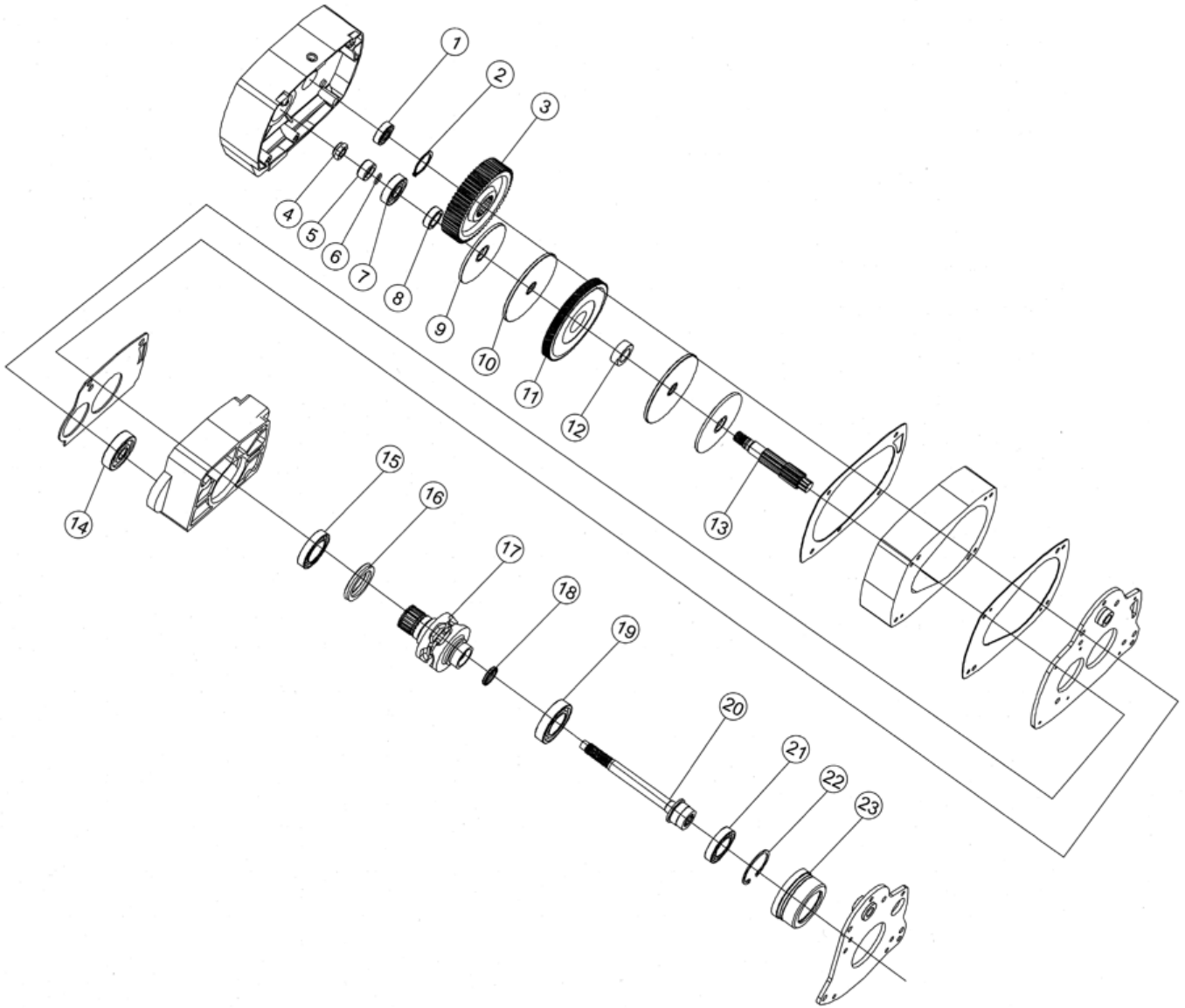

15.8 Gear Box Part List

Drawing No.	Part Description	Part Number					Qty
		½ Ton	1 Ton	2 Ton	3 Ton	5 Ton	
1	Bearing	600-50070	600-50071	600-50072	600-50073	600-50073	1
2	Circlip	600-50074	600-50075	600-50076	600-50077	600-50077	1
3	Output Gear	600-50078	600-50079	600-50080	600-50081	600-50081	1
4	Shaft Nut	600-50082	600-50083	600-50084	600-50085	600-50085	1
5	Oil Seal	600-50086	600-50087	600-50088	600-50089	600-50089	1
6	O Ring	600-50090	600-50091	600-50092	600-50093	600-50093	1
7	Bearing – Intermediate Gear Shaft	600-50094	600-50095	600-50096	600-50097	600-50097	1
8	Spring Plate Bushing	NSS	NSS	NSS	NSS	NSS	1
9	Spring Plate	NSS	NSS	NSS	NSS	NSS	2
10	Brake Disc	NSS	NSS	NSS	NSS	NSS	2
11	Intermediate Gear Includes 8,9,10,12	600-50098	600-50099	600-50100	600-50101	600-50101	1
12	Spring Plate Bushing	NSS	NSS	NSS	NSS	NSS	1
13	Intermediate Gear Shaft	600-50102	600-50103	600-50104	600-50105	600-50105	1
14	Bearing – Intermediate Gear Shaft	600-50106	600-50107	600-50108	600-50109	600-50109	1
15	Bearing – Pocket Wheel	600-50110	600-50111	600-50112	600-50113	600-50113	1
16	Oil Seal	600-50114	600-50115	600-50116	600-50117	600-50117	1
17	Pocket Wheel Includes 18	600-40000	600-40001	600-40002	600-40003	600-40003	1
18	Oil Seal	NSS	NSS	NSS	NSS	NSS	1
19	Bearing – Pocket Wheel	600-50118	600-50119	600-50120	600-50121	600-50121	1
20	Output Shaft	600-50122	600-50123	600-50124	600-50125	600-50125	1
21	Bearing	600-50126	600-50127	600-50128	600-50129	600-50129	1
22	Circlip	600-50130	600-50131	600-50132	600-50133	600-50133	1
23	Motor Base Plate Assembly	600-50134	600-50135	600-50136	600-50137	600-50137	1

15.9 Chain Assembly Diagram

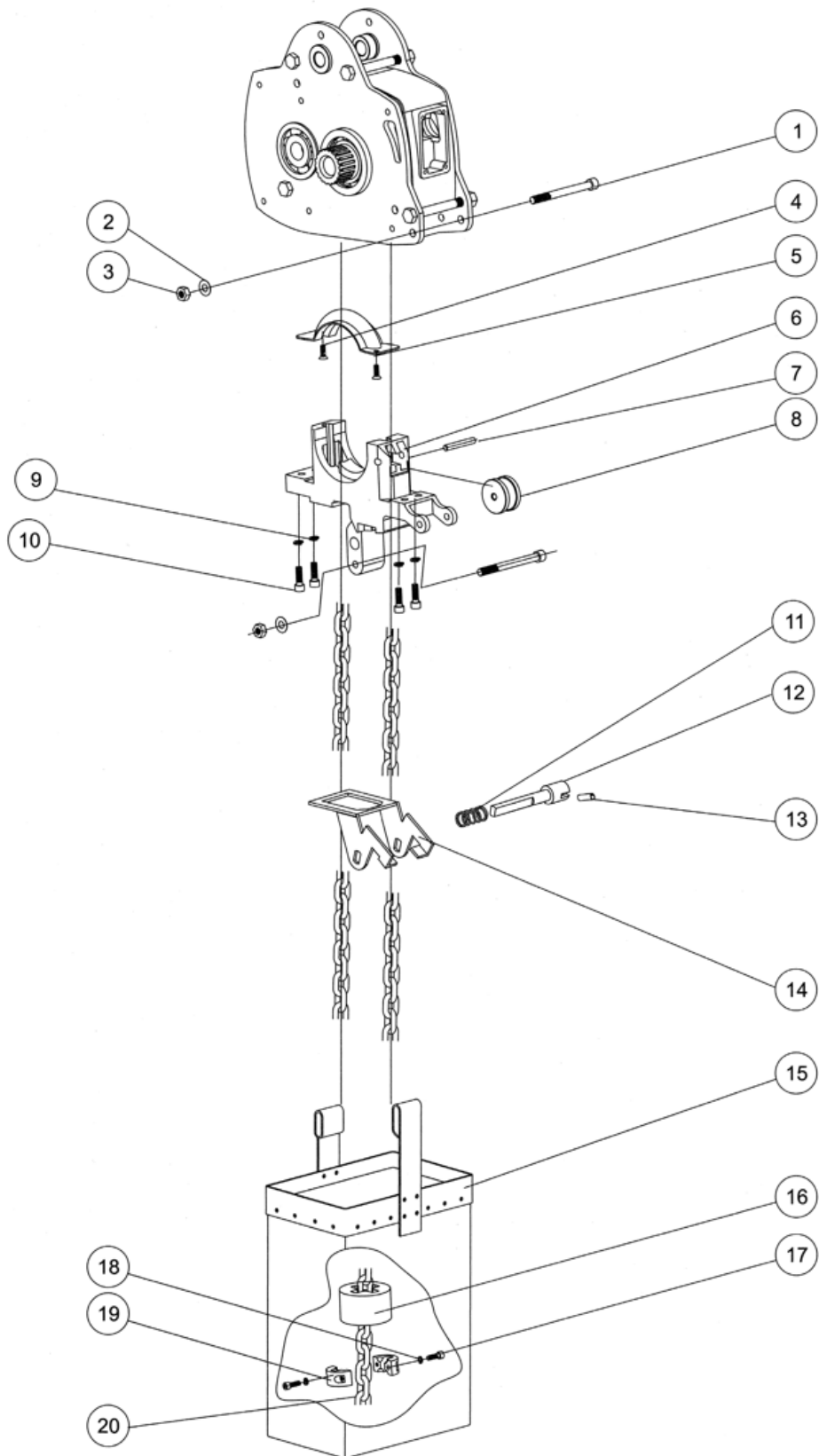

15.10 Chain Assembly Part List

Drawing No.	Part Description	Part Number					Qty
		½ Ton	1 Ton	2 Ton	3 Ton	5 Ton	
1	Bolt	600-50063					2
2	Lock Washer	600-50064	600-50064	600-50064	600-50064	600-50064	2
3	Nut	600-50065	600-50065	600-50065	600-50065	600-50065	2
4	Screw – Upper Chain Guide	600-50066	600-50066	600-50066	600-50066	600-50066	2
5	Upper Chain Guide	600-40008	600-40009	600-40010	600-40011	600-40011	1
6	Lower Chain Guide	600-40004	600-40005	600-40006	600-40007		1
7	Guide Pulley Shaft	600-40025	600-40026	600-40027	600-40028	600-40028	2
8	Guide Pulley	600-40029	600-40030	600-40031	600-40032	600-40032	2
9	Lock Washer	600-50067	600-50067	600-50067	600-50067	600-50067	1
10	Bolt	600-50068	600-50068	600-50068	600-50068	600-50068	1
11	Limit Switch Spring	600-40017	600-40018	600-40019	600-40020	600-40020	1
12	Limit Switch Shaft	600-40021	600-40022	600-40023	600-40024	600-40024	1
13	Roll Pin	600-50069	600-50069	600-50069	600-50069	600-50069	1
14	Chain Stop Rocker – Limit Switch	600-40013	600-40014	600-40015	600-40016	600-40016	1
15	Chain Bag	SCC-0811	SCC-1213	SCC-1416	SCC-1416	SCC-1622	1
16	Rubber Bumper – Chain Stop	600-40036	600-40036	600-40037	600-40038	600-40038	1
17	Cap Bolt	NSS	NSS	NSS	NSS	NSS	2
18	Split Washer	NSS	NSS	NSS	NSS	NSS	2
19	Chain Stop	600-40033	600-40033	600-40034	600-40035	600-40035	1
20	Chain	6.3mm	7.1mm	10mm	11.2mm	11.2mm	

15.11 Electrical Box

Starke ½ Tton:

Early ½ Ton hoists had 1 Primary Contactor- LC1N1210 and 2 Reversing Contactors - LC1N1201

(Part number change for repair purposes.)

- The above numbers are not available in the USA. We have subbed both above numbers with a LC1D12B7.

Sub- LC1D12B7 in USA (1/2 Ton Capacity only)

Starke 1,2,3 & 5 Ton:

Early hoists had 1 Primary Contactor- LC1N2510 and 2 Reversing Contactors - LC1N2501

(Part number change for repair purposes.)

The above numbers are not available in the USA. We have subbed both above numbers with a LC1D25B7.

Sub- LC1D25B7 in USA

16.0 Troubleshooting Guide

Conditions	Reasons	How to Solve
The hoist cannot be operated	<ol style="list-style-type: none"> 1. The power phases are linked wrongly, which results in the start of the phase protection and makes it unable to operate. 2. The power fuse is burned or the no-fuse switch is off. 3. The fuse in the control circuit burns. 4. The power cord or the wire of the control circuit breaks or is not linked properly. 5. The voltage is too low. 6. The motor makes a sound but does not rotate. 7. The emergency switch is pressed (if installed). 8. The contactor is bad. 	<ol style="list-style-type: none"> 1. Exchange the power cords of the two phases. 2. Check whether the current is normal, replace a proper fuse or restart the non-fuse switch. 3. Check whether the current is normal, and replace a proper fuse. 4. Repair or replace the electricity wire that breaks or has bad contact. 5. Measure whether the voltage is over 10% lower than the standard voltage. 6. Check whether the motor phase is correct-repair and make proper insulation. 7. Confirm the reason or pressing the emergency switch. 8a. Operate the hoist manually, if it works properly, it means that the control coil or cable has bad contact – find out the location of bad contact and have it repaired. 8b. If the hoist can not be operated manually, it is necessary to check whether the main power supply is normal. If the main power supply is ok, it is caused by bad contact. If it is unable to output normally, the contactor should be replaced.
The hoist cannot be stopped	The coil of the contactor fuses (it is in short circuit fault).	Replace the contactor.
The brake slides	The motor brake wears.	Replace the friction disc.
The chain/chain wheel of the lower hook makes abnormal noise.	<ol style="list-style-type: none"> 1. The chain is not lubricated enough and properly. 2. The chain wheel is worn. 	<ol style="list-style-type: none"> 1. Lubrication 2. Replace the chain and chain wheel
Electric Leakage	<ol style="list-style-type: none"> 1. Imperfect earth. 2. The dusts in air gather on electrical parts or the humidity is too high. 	<ol style="list-style-type: none"> 1. Provide perfect earth. 2. Keep electrical parts clean and make humidity low.
Oil Leakage	<ol style="list-style-type: none"> 1. The oil plug is not applied. 2. The oil plug is loose. 3. The oil plug gasket is not installed. 4. The gasket is worn or deteriorated. 	<ol style="list-style-type: none"> 1. Install a proper plug. 2. Tighten the plug. 3. Install a proper plug gasket or replace a new gasket.

17.0 Derated Hoist Information

Occasionally a customer may prefer a hoist that has been derated to a lower capacity to provide the hoist mounting area reduced load. Starke hoist derate kits are available by posting a request on the starkeamerica.com website or contacting your Starke products dealer. This manual applies to products that may show lower capacities than those listed in this manual. Check your hoist id tags (not decals) to determine the type of hoist you have and whether this manual is correct for your unit.



Starke Products Warranty

1 Year (12 Month) Parts & Labor Warranty

Unless otherwise specified, Starke guarantees that our products are free from material defects in design and workmanship under normal use, proper maintenance, and service.

This warranty is strictly limited to 12 months for single shift operation or 2,000 hours after installation, or 14 months after shipment, whichever is shorter. Within ten days after defect is found, warrantee must deliver a written notice to Starke providing defect information. All requested warranty information must be received promptly by Starke in no more than 5 business days.

Customer is responsible for all shipping charges on returned/warrantable items. Starke will cover the repair (parts and labor) at no charge or provide a replacement item at Starke's discretion.

This warranty does not cover defects or damage caused by acts of God, unusual wear and tear, improper use, or improper maintenance by the user. No responsibility for consequential damage is expressed or implied, and the responsibility under this warranty/guaranty is limited to the repair or replacement of the defective materials. Repair or replacement of the item is fully at the discretion of Starke.

ALL OTHER REPRESENTATIONS, EXPRESS OR IMPLIED, WARRANTY, OR LIABILITY RELATING TO THE CONDITION OR USE OF THE PRODUCT ARE SPECIFICALLY DISAVOWED, AND IN NO EVENT SHALL STARKE BE LIABLE TO BUYER, OR ANY THIRD PARTY, FOR ANY DIRECT OR INDIRECT CONSEQUENTIAL OR INCIDENTAL DAMAGES

STARKE

Starkeamerica.com/contact-us/



Contact Your Starke Representative for More Information on Products to Help Maximize Your Workplace Efficiency



Hoists & Trolleys

Crane Components



Electrification

Crane Kits



Slings



Safety